

ACTUATOR TYPE - E10

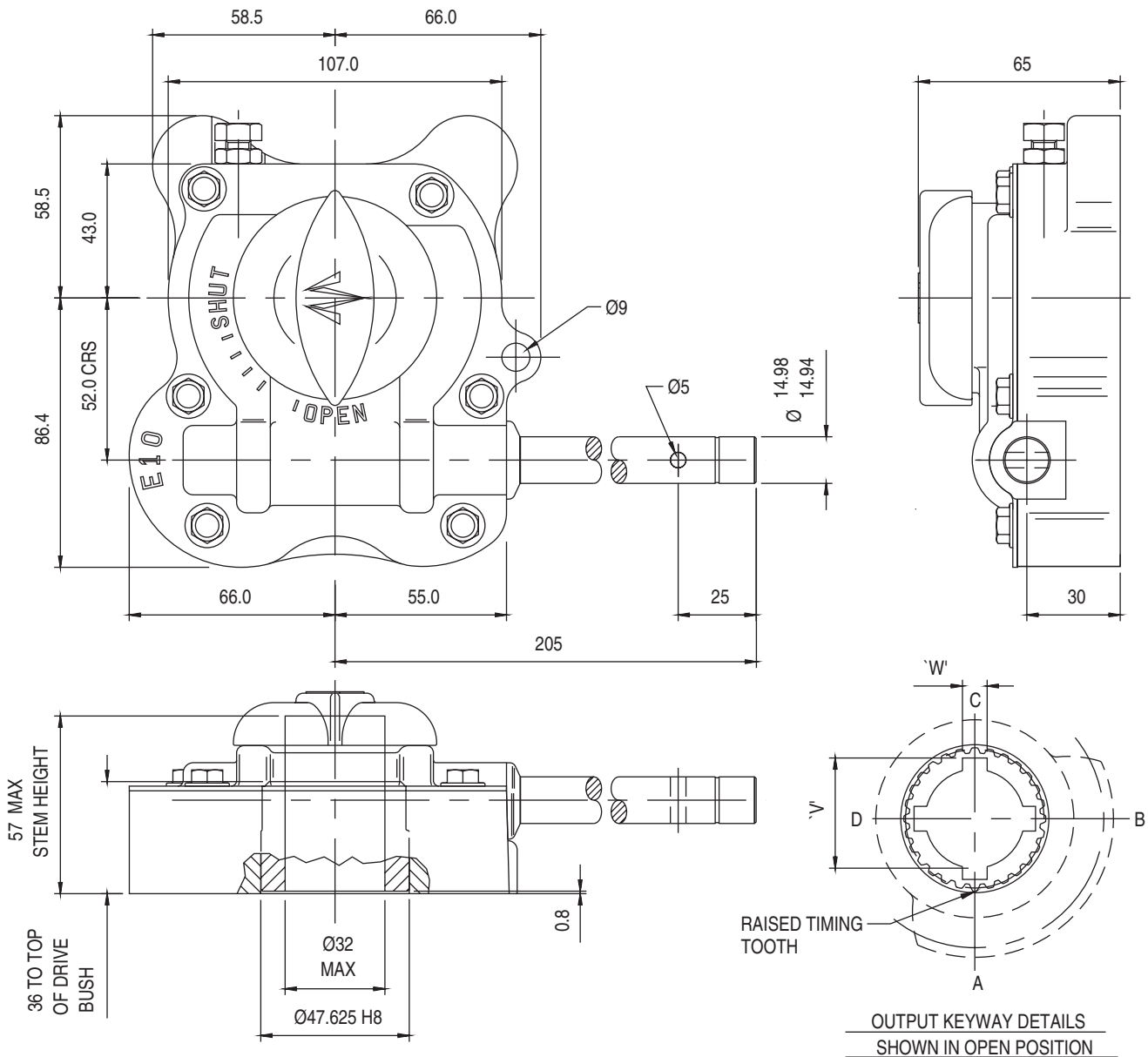

GENERAL INFORMATION

TRAVEL.....90° +/- 5° AT CLOSED END
 RATIO.....40:1
 TURNS TO CLOSE.....10

MECHANICAL ADVANTAGE.....7.0 +/- 10%
 MAXIMUM OUTPUT TORQUE.....500 Nm
 MAXIMUM INPUT TORQUE.....71.4 Nm

MOUNTING HOLE DETAIL: PREFERRED....F07, F10 & F12
 MAXIMUM.....F12 (4 x M12 ON 125 PCD)
 MINIMUM.....F07 (4 x M8 ON 70 PCD)

APPROXIMATE WEIGHT.....3.7 Kg (excluding handwheel)

HANDWHEEL DATA	
TYPE	DIA
SR10	250

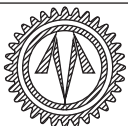

OPPERMAN MASTERGEAR

Hambridge Road, Newbury, Berkshire, RG14 5TS. ENGLAND
 Telephone: (01635) 811500 Telefax: (01635) 811501

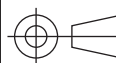

DIMENSIONS IN	SCALE	DRAWING No.
MM	1:2	ME-15406

THIS DRAWING/DESIGN IS THE PROPERTY OF OPPERMAN MASTERGEAR LTD. AND ©
 MUST NOT BE USED OR COPIED WITHOUT THEIR SPECIFIC WRITTEN CONSENT.

REV. A
 23OCT98