

A43 BEVEL GEAR ISO

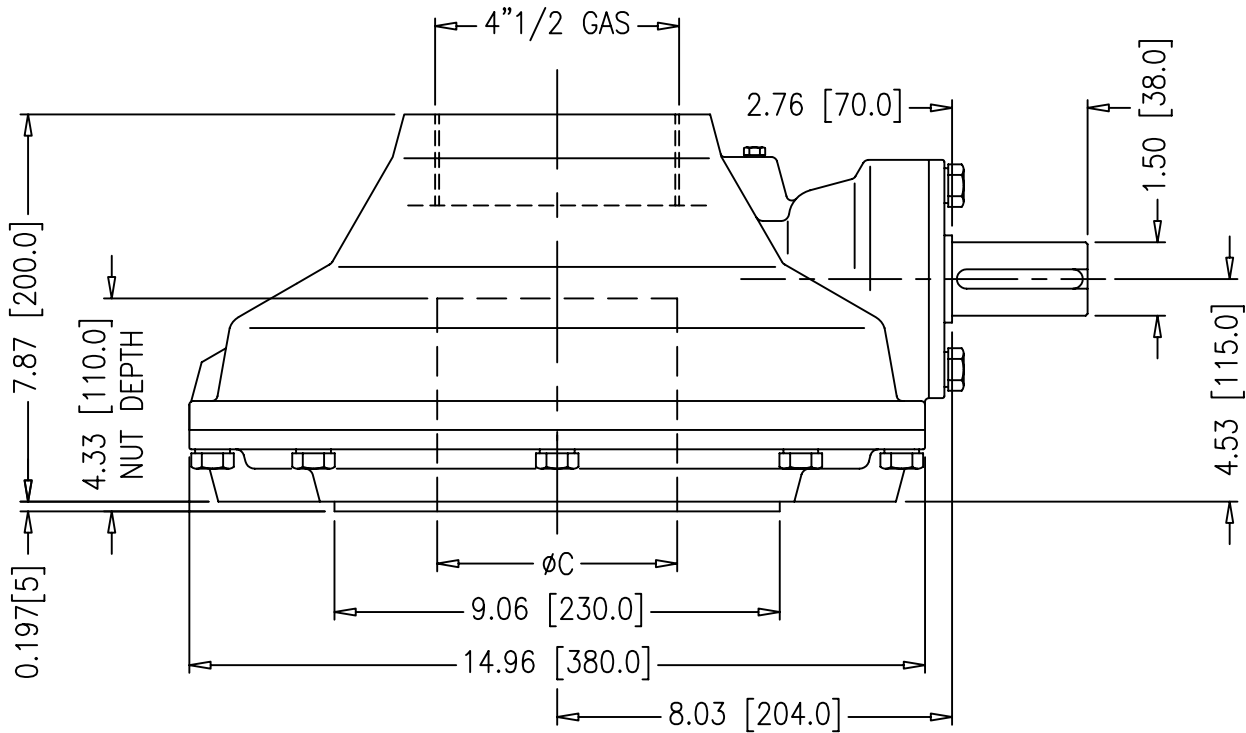

M20 TAP ~ 8 HOLES
ON 11.75 [298mm] B.C.D.

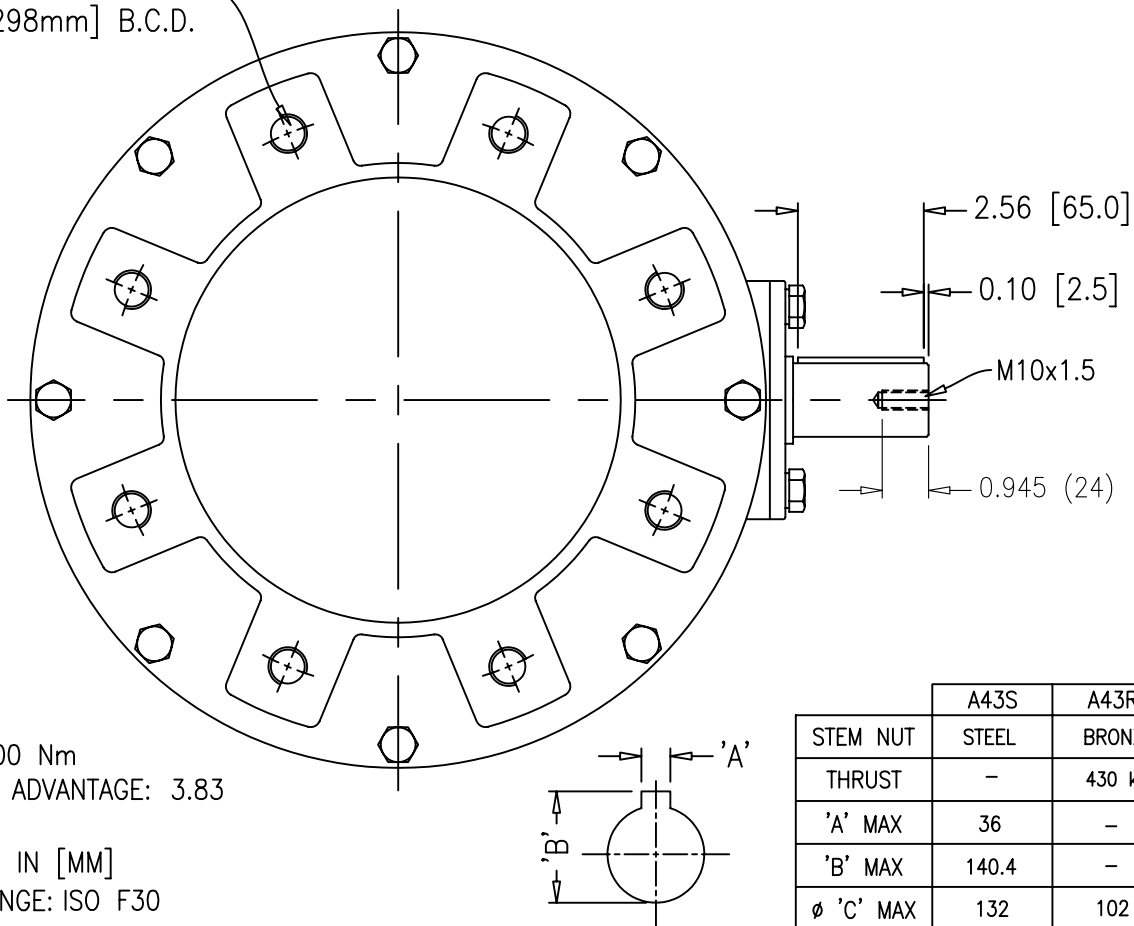

NOTES:

1. TORQUE: 3800 Nm
2. MECHANICAL ADVANTAGE: 3.83
3. RATIO: 4.5:1
4. DIMENSIONS: IN [MM]
5. OUTPUT FLANGE: ISO F30

	A43S	A43R
STEM NUT	STEEL	BRONZE
THRUST	-	430 kN
'A' MAX	36	-
'B' MAX	140.4	-
ϕ 'C' MAX	132	102



COSTRUZIONI MECCANICHE LEGNANESI

MASTERGEAR

DIVISION OF REGAL-BELOIT CORPORATION
5466 EAST ROCKTON RD. SOUTH BELOIT, IL 61080

THIS DRAWING/DESIGN IS THE PROPERTY OF MASTERGEAR. AND MUST NOT BE USED WITHOUT THEIR SPECIFIC WRITTEN CONSENT. ©

DO NOT SCALE
APPROVED BY
LD

DRAWING No.
A43 ISO
REV.0
16-04-03